

# 865 Preformed Loop Installation Instructions

The 865 Preformed Detector Loop is shipped partially assembled. It consists of five turns of #16 insulated machine tool wire inside a pre-assembled and sealed rectangle of PVC pipe. Exiting the rectangle are two lead wires which have been twisted together. Also included is one 48" long PVC pipe, one 11" long PVC pipe, and one 90 degree elbow. These three pieces are used to make the loop lead conduit into the menu board/speaker post.

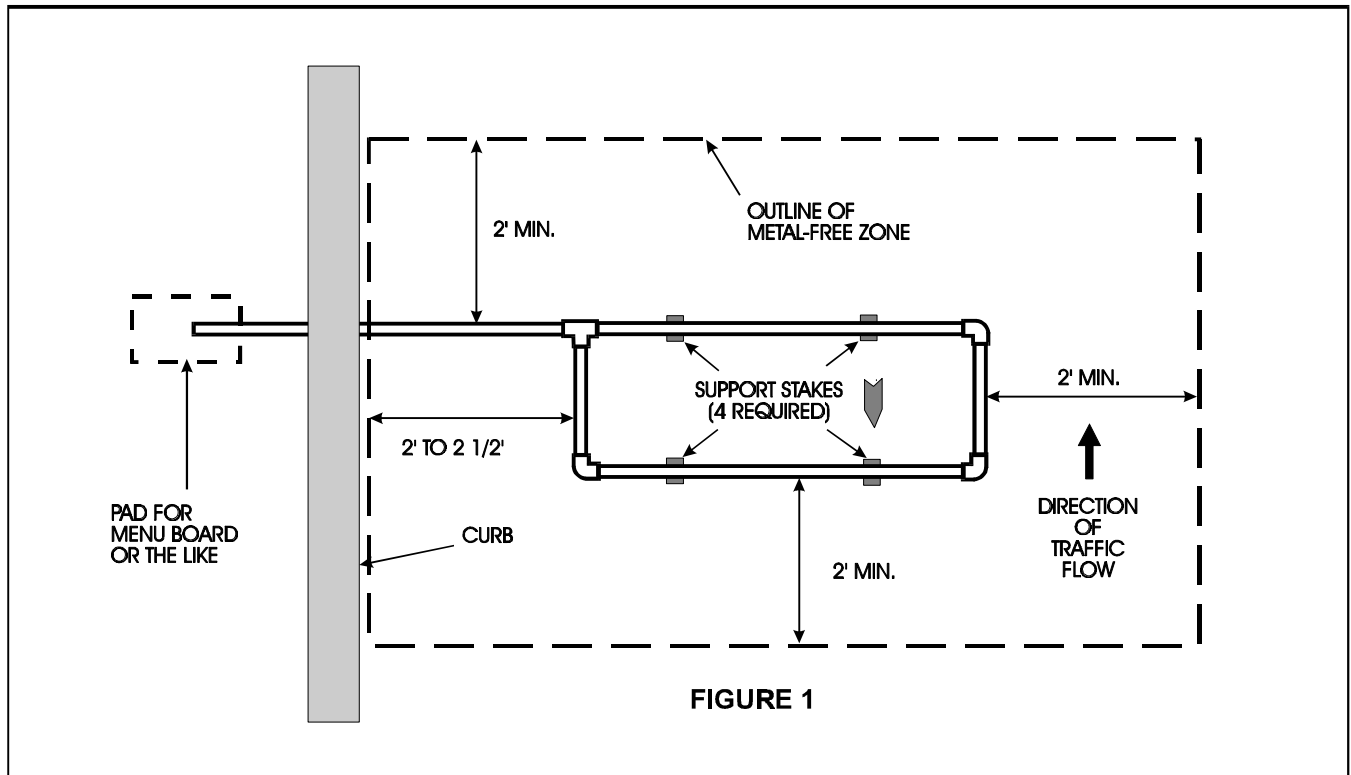

## PRECAUTIONS

(Refer to Figure 1)

1. The loop should not be closer than five feet (5') from any magnetic interference above ground such as a storage tank, a dumpster, or other large metal object.
2. No part of the loop should be within two feet (2') of reinforcement rods in the surrounding pavement.
3. The loop should not be situated directly over any large metal object in the ground within five feet (5') of the surface.

## CONCRETE PAD PREPARATION

(Refer to Figure 2)

Excavate deep enough to install a stone or gravel base. The finished pad must cover the loop with a maximum of two inches (2") of concrete.

## ASPHALT PAD PREPARATION

(Refer to Figure 3)

1. Excavate to a minimum of four inches (4") below the proposed finished pavement.
2. Install a sand base that will allow a maximum of two inches (2") of asphalt pavement above the loop.

3. Dig a trench for the loop lead conduit at the same depth as the loop.
4. Cut a slot through the curb to accept the lead wire conduit if necessary.

## POSITIONING THE LOOP

1. Place the loop on the ground as shown in Figure 1.
2. Refer to Figure 1 and measure from the "TEE" to the pad for the menu board.
3. Mark and cut the 4' piece of loop lead conduit to this dimension.
4. Thread the loop wires through the cut loop lead conduit and cement the loop lead conduit to the loop "TEE"
5. Thread the loop lead wires through the 90 degree elbow and cement the elbow to the loop lead conduit.
6. Thread the loop lead wire through the 11" piece of PVC pipe and cement this piece to the elbow.
7. On the pavement, mark off and outline that extends at least two feet (2') beyond any portion of the loop and its cable leads.
8. Remove metal reinforcing rods or other metal objects less than five feet (5') below the loop and within the perimeter of this metal-free area.

## 865 LOOP INSTALLATION INSTRUCTIONS (CONTINUED...)

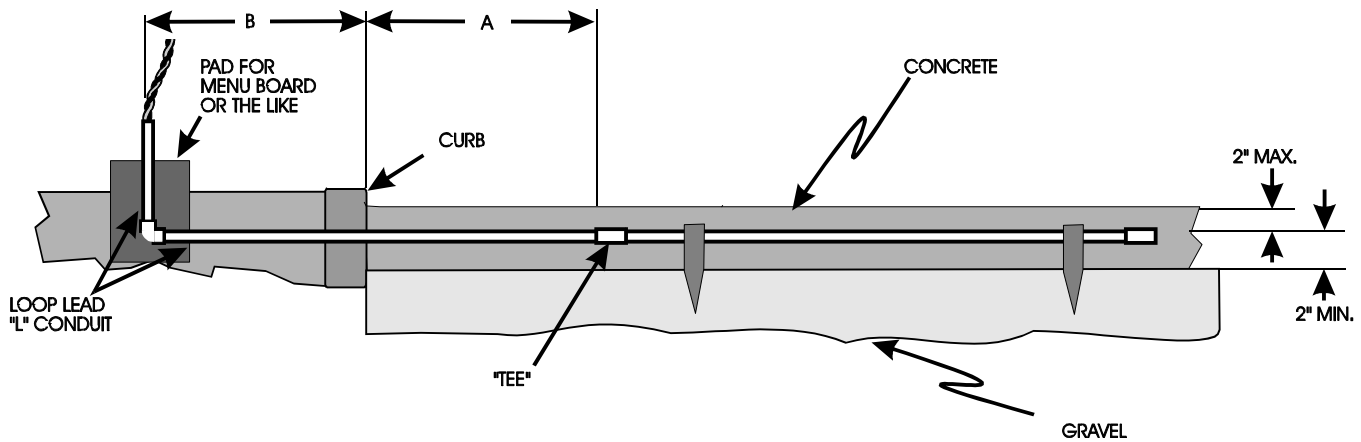

FIGURE 2

### EMBEDDING THE LOOP IN CONCRETE

1. Set the loop in place using four notched stakes in the gravel base to suspend it while concrete is being poured.
2. Pour concrete below and above the loop to the finished grade.

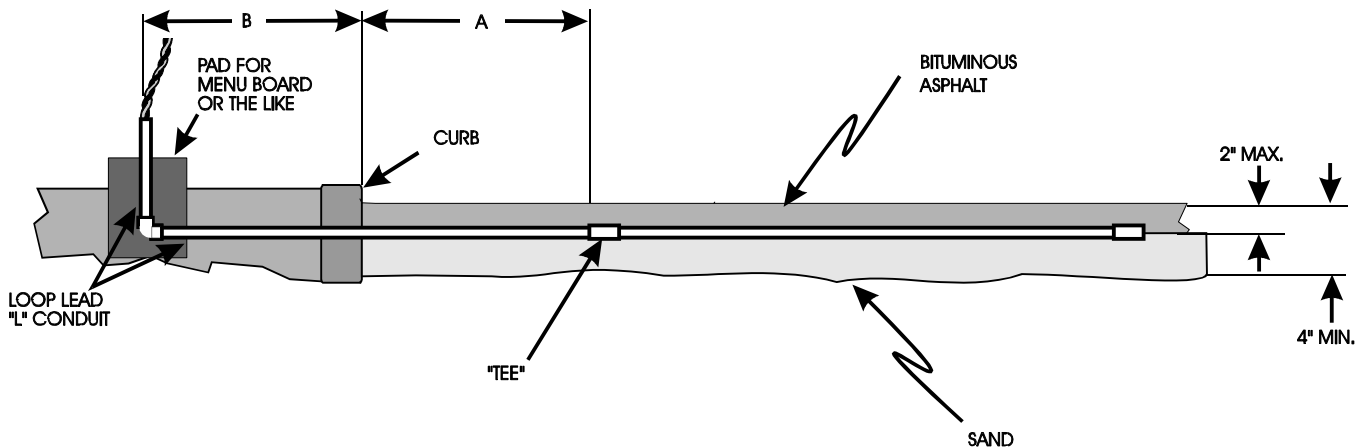

FIGURE 3

### EMBEDDING THE LOOP IN ASPHALT

1. Press the loop onto the sand base so that sand supports all parts of the loop.
2. Lay a maximum of two inches (2") of asphalt above the loop.
3. Carefully roll the surface with a small roller or tamp. Do not use a street roller; the weight may damage the PVC conduit.
4. Patch the slot in the curb with paving material.
5. Back-fill over the trench for the cable lead conduit.
6. The loop is ready for connection to the extension cable.

See LOOP EXTENSION CABLE INSTALLATION for instruction.